

Raised Panel Doors for Cooler

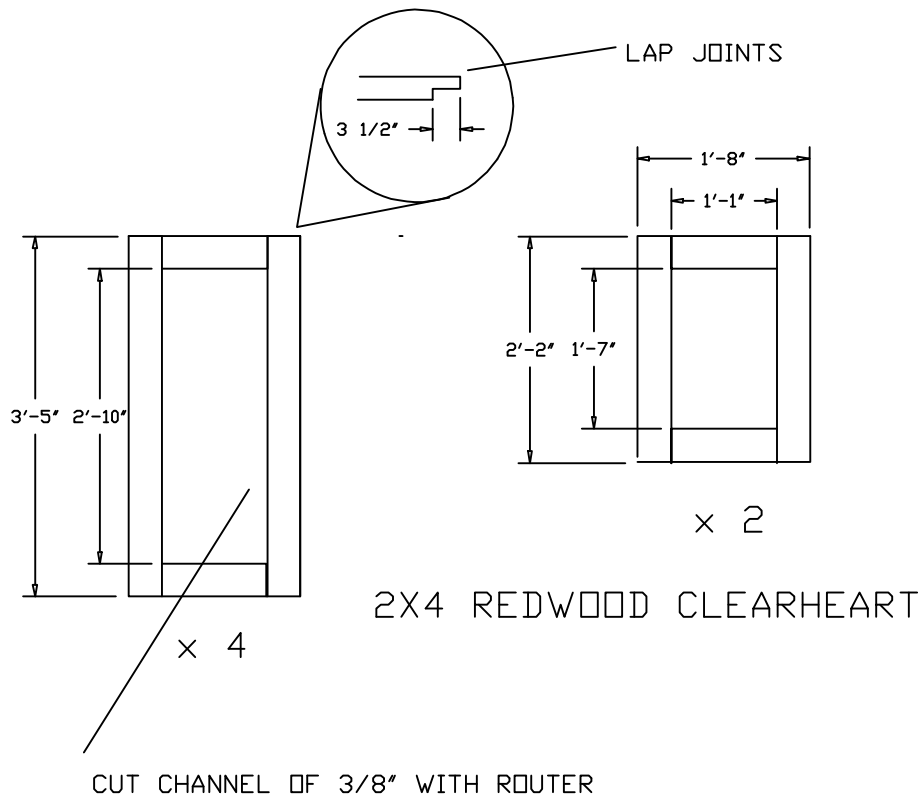

The doors are to be cut but not glued together until the center panels are inserted.

Later revisions had the doors reinforced with 1/2 plywood glued and screwed in to the back of the doors. Otherwise, the doors couldn't hold up to the stress of slamming the closed.

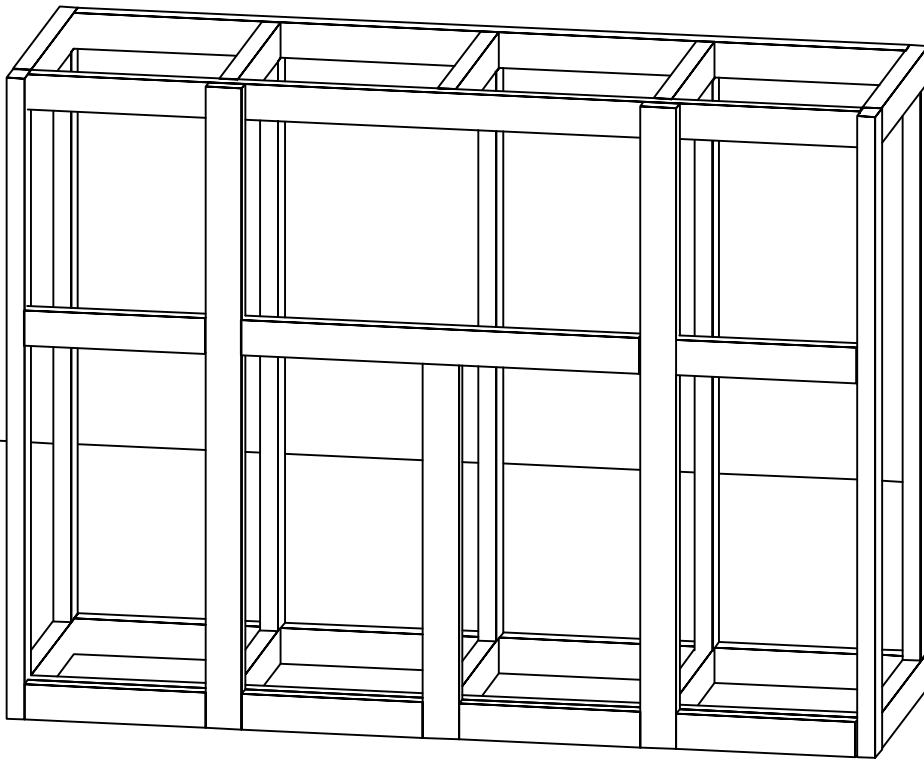

The basic frame of the cooler. Kiln dried Redwood frame screwed together with 2-3" long screws. Later. Plywood added to the outside and inside with insulation material in between.

